

FISCHBEIN®

Model 400 NS™ Foldover

Plain Sew

Fischbein Model 400 NS™ Foldover

The Fischbein Model 400 NS™ Foldover sets the industry standard for quality and cost-effective bag sewing. Operating at adjustable speeds up to 45 linear feet per minute, the Model 400 NS™ comes with an infeed system that automatically folds the bag top over creating a unique fold and sew concept. This results in a stronger bag closure and is an alternative to tape sew for select applications.



EVERYTHING IN BAGGING EQUIPMENT™



Fischbein® Model 400 NS™ Foldover

Plain Sew

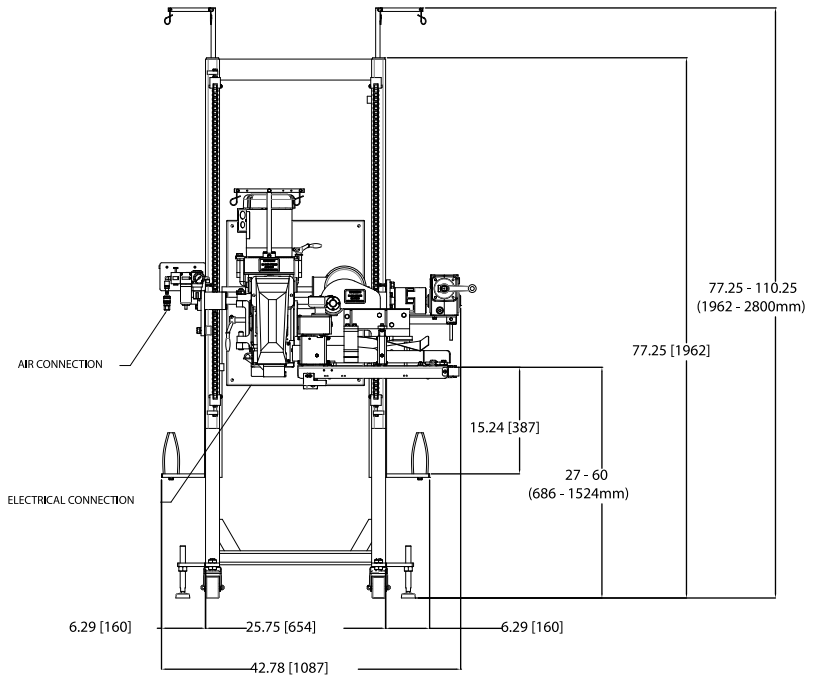
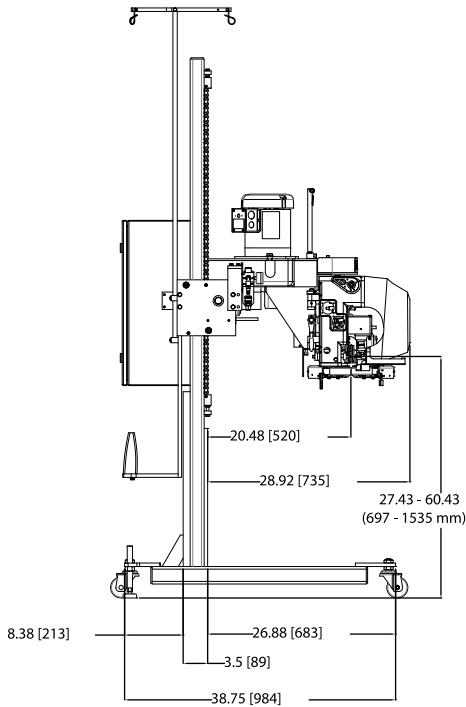

400NS WITH FOLD OVER INFEED

FEATURES

BAG TYPES

Used to produce sewn, folded closures on pillow style woven and laminated woven polypropylene open mouth bags. (No multi-wall gusseted paper bags.)

FOLDOVER INFEED SYSTEM

Fast. Safe. Automated. The leading edge of the bag is fed into the infeed, folded over and automatically guided through the bag sewing process.

EMPRESS 100 SEWING HEAD

With its self-lubricating system, the Empress 100 delivers trouble-free, smooth performance with low vibration. Operating speed is adjustable from 35 to 45 linear feet per minute for this application.

AIR THREAD-PUSHER

Without operator assistance, the air thread-pusher automatically directs the thread into the system's cutting knife.

SWING FEATURE

Fischbein's exclusive sewing-head swing feature makes threading the 400 NS™ a snap, and provides full access for cleaning and easy head removal.

OPTIONS

- Direct drive VFD package for synchronous sewing
- Motor starter and contactor for conveyer
- Optical thread break and oil sensor package
- 575 VAC
- Tagger Infeed
- Rotary knife thread cutter
- Corrosion resistant package with NEMA 4 rated electrics

SPECIFICATIONS

- Dimensions: L 46 in (117 cm), D 41 in (104 cm), H 78 in (198 cm)
- Speed: Up to 45 linear feet per minute
- Electric (NEMA 12): 230/380/460 VAC, 3 PH, 50/60 Hz
- Air: 1 cfm @ 90 PSI

BAGS

- Bag Types: Multi-wall paper, woven polypropylene, and jute bags, either pillow-style or gusseted.
- Bag Thickness: Maximum 12 mils
- Free Bag Top: Minimum 6 in (15.2 cm)

APPLICATIONS

- Fertilizers/Minerals
- Cat Litter
- Feed Additives
- Bakery Mixes
- Chemicals
- Pet Food
- Agricultural Seed
- Powdered Dairy Products

570 - 323 - 9030

**HAMER
FISCHBEIN®**

A DURAVANT COMPANY

Specifications are subject to change without notice.

