

FISCHBEIN®

Model HAS 220™

Hot Air Sealer

Fischbein Model HAS 220™

The Fischbein Model HAS 220 Hot Air Sealer provides efficient, cost effective sealing of pillow style or bottom gusset pre-made polyethylene bags up to 60 feet per minute. Standard DC variable speed controls synchronize sealer to conveyor speeds.



EVERYTHING IN BAGGING EQUIPMENT™



Fischbein Model HAS 220™

Hot Air Sealer

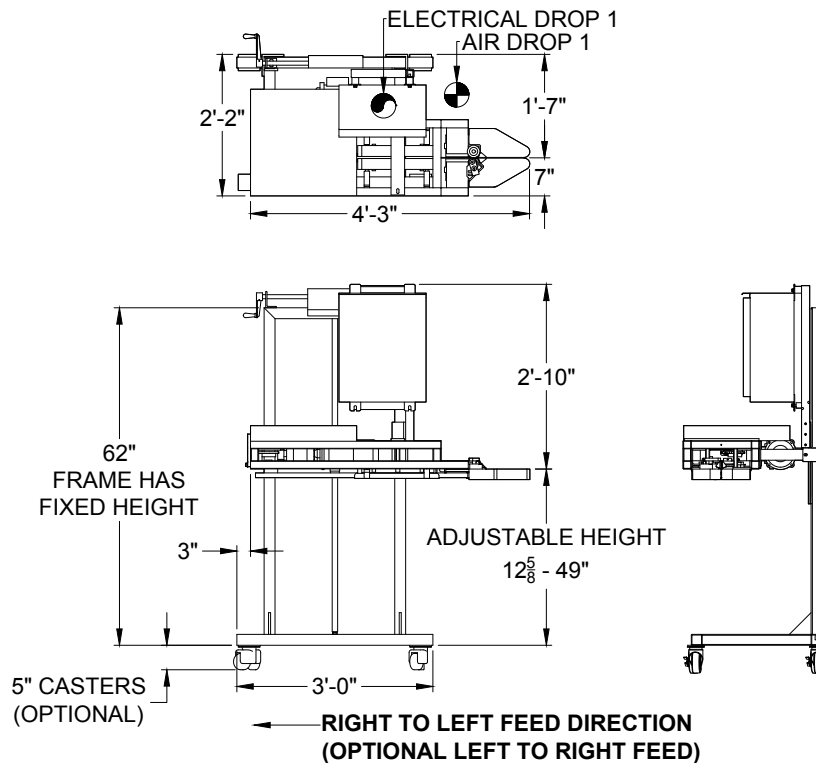

FEATURES

BAG TYPES

Seals pillow style, non-side gusseted bags without the use of bands.

CONSISTENT, CONTINUOUS PRODUCTION

Standard DC variable speed controls match sealer and conveyor speeds for maximum bag production.

NO BANDS

Eliminate maintenance costs and downtime - no bands required.

USER FRIENDLY CONTROLS

Safe and easy to use control panel with digital temperature display, air pressure detector, and automatic heater burnout detector to ensure seal quality.

OPTIONS

- Industrial casters for portability
- Left to right operation
- Extra heat
- Seal Cooling
- Embossing Coder

SPECIFICATIONS

- Dimensions: L 36 in (91.4 cm), D 26 in (66 cm), H 62 in (157.5 cm)
- Speed: Up to 60 linear feet per minute
- Electric (NEMA 12): 230 VAC-1PH-60 Hz, 23 FLA
- Air: 6 cfm @ 80 PSI. Up to 10 cfm with Cooling Option.
- Weight: 550 lb (uncrated)

BAGS

- Bag Types: Heat sealable structures in a wide range of poly bags.
- Bag Thickness: Min. 2 mils; Max. 8 mils

APPLICATIONS

- Fertilizers
- Minerals
- Chemicals
- Cat Litter
- Powdered Dairy Products
- Pet Food
- Feed Additives
- Agricultural Seed
- Bakery Mixes

570 - 323 - 9030

**HAMER
FISCHBEIN®**

A DURAVANT COMPANY

Specifications are subject to change without notice.

