

Gross Weigh Scale

Hamer Model HGB[™]

The Hamer Model HGB[™] mechanical gross weigh scale is a simple and economical manual bagging solution for free-flowing, granular products. The Model HGB is easy to install, low cost to operate and requires no electrical power or compressed air.



Hamer™ Model HGB™

Gross Weigh Scale

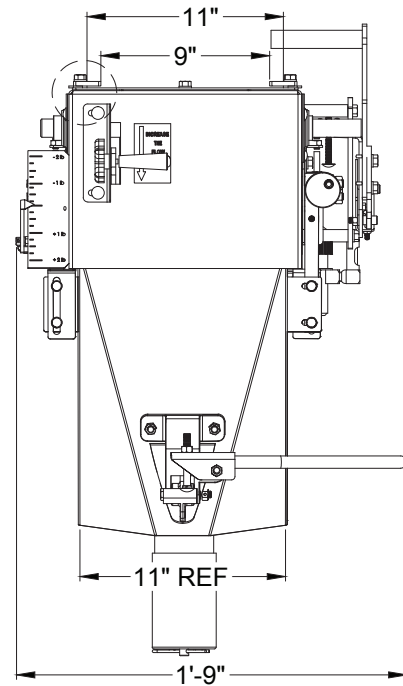
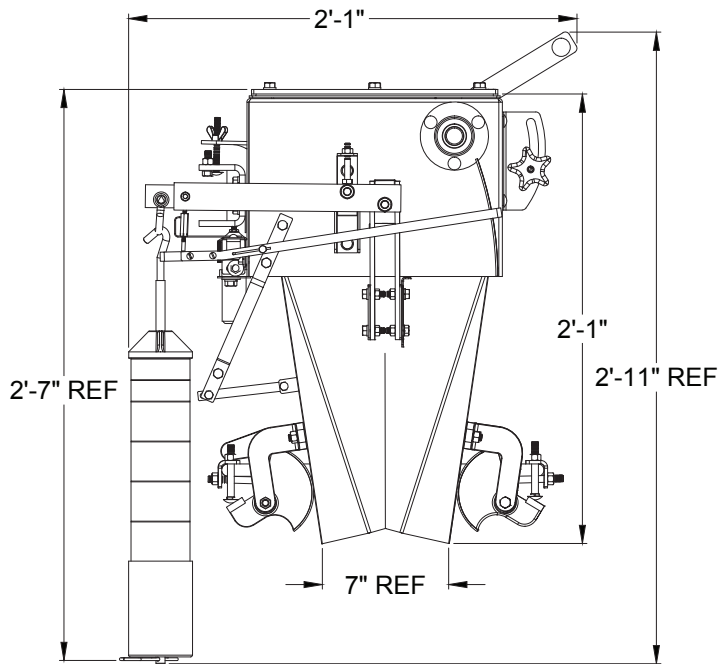

FEATURES

- 6 to 8 BPM fill rate
- Accuracy: +/- 7.0 oz (200 g), product dependent
- Easy weight adjustment
- Weight range 10 Lb to 150 Lb (5 Kg to 70 Kg)
- Mechanical indicator for weight variance
- Adjustable flow control gate
- In-feed size: 7 in x 9 in (17.8 x 22.8 cm)

OPTIONS

- Mild Steel or Stainless Steel
- Measurement in Lbs or Kgs
- Dust Tight System

SPECIFICATIONS

- Dimensions: W 21.5 in (54.4 cm); H 34.5 in (87.9 cm); D 24.5 in (62.4 cm)
- Electric: Not required
- Air: Not required

SPOUT SIZES

- For Large Bag spout: 16 in (40.6 cm) minimum bag opening width
- For Small Bag spout: 12.5 in. (31.7 cm) minimum bag opening width

APPLICATIONS

- | | | |
|---------------------|------------------|--------------|
| • Fertilizers | • Chemicals | • Minerals |
| • Agricultural Seed | • Food | • Pet Food |
| • Animal Feed | • Feed Additives | • Cat Litter |

570 - 323 - 9030

 **HAMER
FISCHBEIN®**

A DURAVANT COMPANY

Specifications are subject to change without notice.