



Model 600NW+
Model 200NW+
Net Weigh Scales

High Speed

High Accuracy

High Repeatability



The Hamer Models 600NW+ and 200NW+ are the only net weigh fillers available that offer combined high speed and high accuracy performance. These enhanced technology scales set a new standard for net weigh filling.

EVERYTHING IN BAGGING EQUIPMENT™



Faster Return on Investment

After years of research and hundreds of net weigh installations, Hamer-Fischbein engineering developed our new enhanced technology signal processing system. This new technology improves repeatable filling speeds by 20% and repeatable accuracy by 30%, taking net weigh performance into unheard of processing speeds and fill accuracy. When comparing Hamer 600NW+ and 200NW+ performance to other manufacturers' products, the results are startling.

ACCURACY (High speed, repeatable)

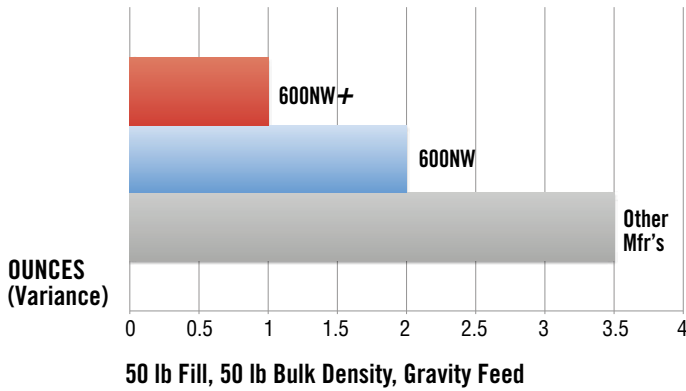

MAXIMUM SPEED (Simplex)

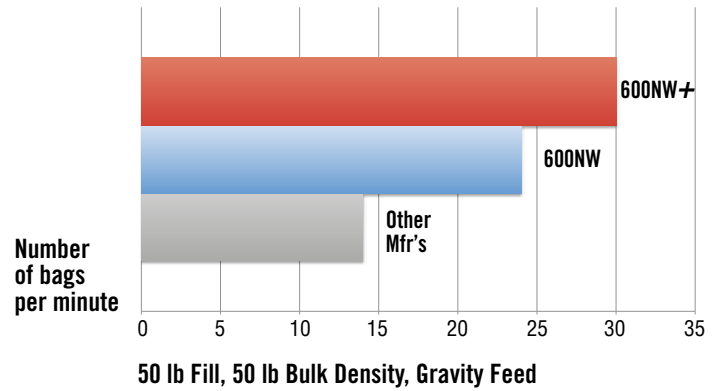

New 200NW+ Small Weighment

Based on the same robust design as the Model 600NW+, but in a much smaller format, the Model 200NW+ offers heavy-duty industrial quality dosing of small weighments. The all structural steel or optional stainless steel construction mirrors the Model 600NW+ design. Able to reliably process weighments of .5 lb to 30 lb, it processes at speeds of 30, 60, 80+ weighments per minute in Simplex, Duplex, Triplex or Quad configurations. Offered in pneumatic or servo controlled gravity feed configurations only.

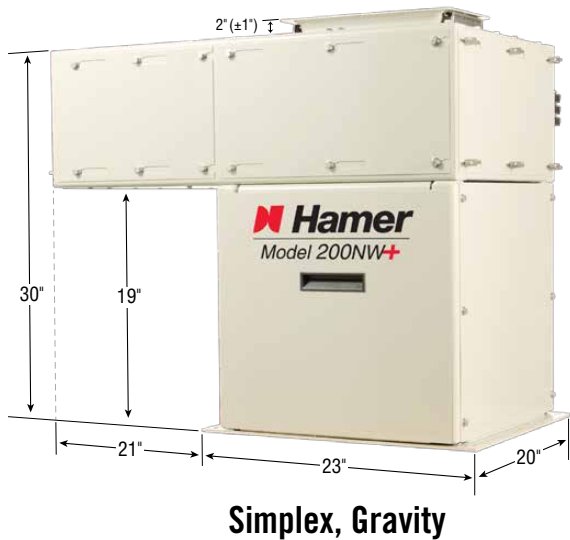



Models 600NW+ and 200NW+

Fast, Accurate, Durable, Reliable

Increased accuracy reduces product give away. Direct mounted load cells featuring our exclusive Truweigh™ dampening system are faster responding and more accurate than traditional scale designs using transfer rods, flexures and suspended weigh hoppers.

Fast processing time. Precision load cells, cutting edge high speed electronics, and an aggressive weigh hopper design with steep door angles and expanded length/width dimensions speed material dispensing. No design is faster.

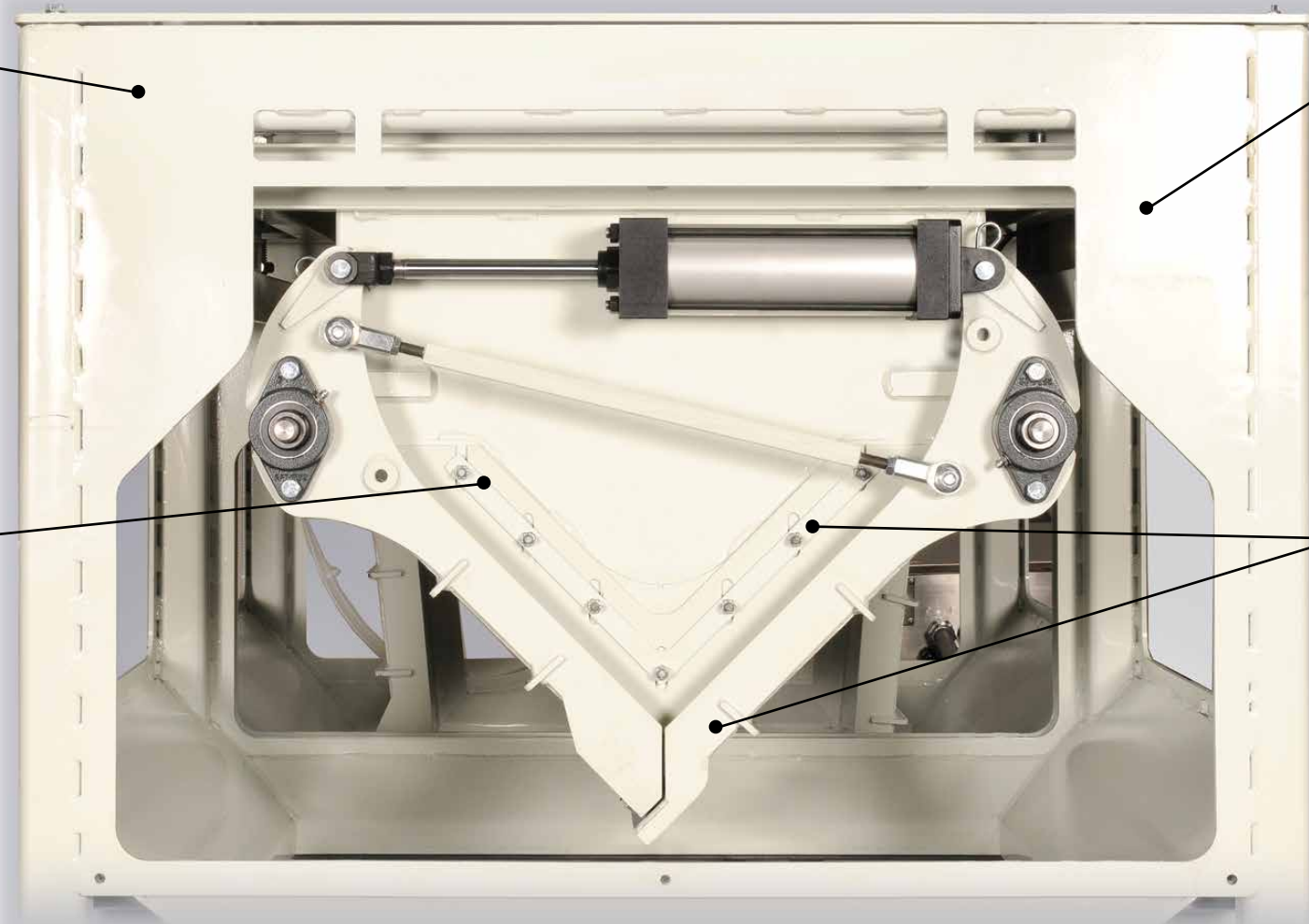

Model 600NW+ pictured

Easy to maintain. Removable access doors on scale and feeder for product clean out. Simple design with few moving parts.

Steel Where You Need It.™ Heavy gauge steel is used throughout the design, especially in the weigh bucket assembly. Hamer scales have almost twice the steel of competitive designs.

The Model 200NW+ can be configured into a high speed Duplex, Triplex or Quad weighing system.



Model 200NW+ Triplex

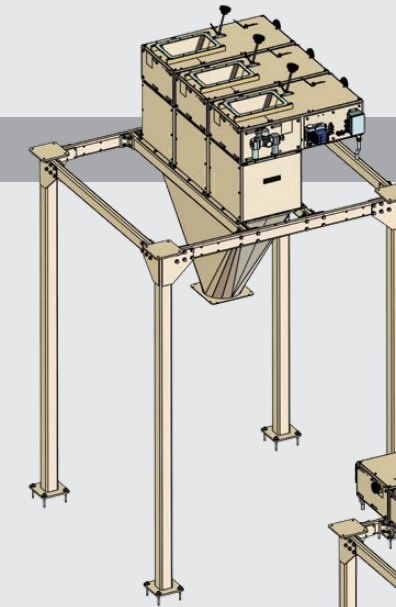

Model 200NW+ Quad

Up to 80+ weighments/min. depending on product characteristics.



GRAVITY

- Products: Free Flowing, Granular
- Heavy duty two position pneumatic control
- Easy adjust bulk/dribble



SERVO GRAVITY

- Products: Free Flowing, Granular
- Digitally controlled servo motor
- Precise control for bulk/dribble
- Extremely high speed



BELT

- Products: Semi-free flowing
- Two Speed VFD Controlled
- Exclusive side slide out
- Lag drive/wing take up pulley
- Cut off gate



AUGER

- Products: Non-free flowing, Powders
- Two Speed VFD Controlled
- Dual Auger Design
- Pneumatic slide cut off gate
- Augers easily removed for cleaning

600NW+ Simplex					200NW+ Simplex	
Feeder	Gravity	Servo Gravity	Belt	Auger	Gravity	Servo Gravity
Accuracy	Up to ± 0.5 oz. (15 g) @ 2 Sigma	Up to ± 0.5 oz. (15 g) @ 2 Sigma	Up to ± 1.4 oz. (40 g) @ 2 Sigma	Up to ± 1.4 oz. (40 g) @ 2 Sigma	Up to ± 0.5 oz. (15 g) @ 2 Sigma	Up to ± 0.5 oz. (15 g) @ 2 Sigma
Speed	Up to 26	Up to 30	Up to 18	Up to 10	Up to 26	Up to 30
Weight Range	10 lb to 110 lb (5 kg to 50 kg)			.5 to 30 lb (.23 kg to 13 kg)		
Weigh Hopper Capacity	3.5 cu ft (.10 cu m)			.8 cu ft (.02 cu m)		
Stated speeds are dependent upon product flow characteristics, material size and weightment size. Duplex, Triplex and Quad configurations provide higher speeds.						

Corrosion Resistant Solutions

Bagging chemicals such as fertilizer, salt, calcium chloride, ice melt, and metal oxides with high corrosive properties can cause excessive wear and tear on your net weigh scale. The Hamer Model 600NW+ and 200NW+ are available in 304 stainless steel construction on the main scale assembly, and 304 or 316 stainless steel on contact points, gravity gate and weigh bucket.



Stainless steel gravity gate and weigh bucket, with hydraulic hinge.

Selecting the right material feeder



Product Characteristics

One of the most important aspects in defining the application of the proper scale is confirming your specific product characteristics. Product characteristics can include:

- Powder
- Granular
- Free Flowing
- Large Non-standard Pieces
- Abrasive
- Non-Free Flowing
- Compaction
- Aerated
- High Moisture Content
- Dust Content
- Fines Content
- Corrosive
- Sticky
- Hygroscopic

Mesh Size

Not all fine products are powders. When defining your product, confirm its mesh size. Mesh is determined by how many openings are required in a 1" square of screen to allow your material to flow. Consult a U.S. Mesh size chart to confirm your product's Mesh size. Typically products that are 200 Mesh or higher are considered fine powders.

Bulk Density

Bulk Density is typically provided in Pounds per Cubic Foot. For example many chemical fertilizer products range in the 50-65 lb per cubic foot bulk density. The higher the bulk density, typically the better (faster) the product will flow and the more weighments per minute you will achieve.

Flow Characteristics	Angle of Repose	Net Weigh Feeder Type
Very Free Flowing	Flows well at angles of 30 degrees and less	Gravity/Servo Gravity
Free Flowing	Flows well at angles of 30-45 degrees	Gravity/Servo Gravity
Sluggish	Flows well at angles greater than 45 degrees	Belt/Auger
Non-Free Flowing	Requires assistance to flow	Belt/Auger

Hamer™ Model 600NW+ and Model 200NW+

STANDARD FEATURES:

- High accuracy weighing
- High speed operation
- Heavy gauge steel weigh hopper
- Reinforced steel weigh hopper doors
- 4" (10.2 cm) dust collection port(s)
- Truweigh™ mechanical load damping
- Rugged platform style single point load cells
- Industrial air cylinders, valves and pneumatics
- Easy access removable scale side panels
- Easy access removable panels for feeder options
- UL Listed Controls
- Model 600NW+ Multiple Feeder designs include:
 - Gravity
 - Two Speed VFD Belt
 - Vibratory
 - Servo Gravity
 - Gravity/Vibratory
 - Dual Auger
- Model 200NW+ Feeder Designs
 - Gravity
 - Servo Gravity
- High resolution electronic scale indicator with:
 - Programmable Checkweigh
 - Scale status indicators
 - Surge hopper/silo fill level status
 - Simple programming screens
 - 100 product storage
 - Learn Pre-act

OPTIONS

- Hand Bagging Spouts: Center Grip, Dust Tight, Clamshell
- 304 Stainless steel construction
- 304/316 Stainless steel product contact
- Collating chutes for hand or automated bagging
- Linear actuator control on belt feed product gate
- Ethernet Connectivity
- Scale Support Structures
- Full bag conveyors, bag top closers
- Automated bagging systems

SPECIFICATIONS

- Two part epoxy paint
- Operating Temperature 40° F (4.4° C) to 110° F (43.3° C)
- Air: 8 cfm @ 80 PSI
- Power:
 - Gravity: 110 VAC, 1 PH, 60/50 Hz
 - Belt Feed: 230 VAC, 3 PH, 60/50 Hz,
 - Vibratory Feed: 230 VAC, 3 PH, 60/50 Hz
 - Controller: 110 VAC, 1 PH, 60 Hz, NEMA 6
- Scale Dimensions (approx):
 - Model 600NW+ L 52" (132 cm), W 29" (74 cm), H 47" (119 cm)
 - Model 200NW+ L 44" (112 cm), W 20" (51 cm), H 32" (81 cm)
- Weigh hopper sizes:
 - Model 600NW+ 3.5 cu ft (.10 cu m)
 - Model 200NW+ .8 cu ft (.02 cu m)

570 - 323 - 9030

Your authorized Hamer-Fischbein representative:



Specifications are subject to change without notice.

A DURAVANT COMPANY

